

### ENGLISH

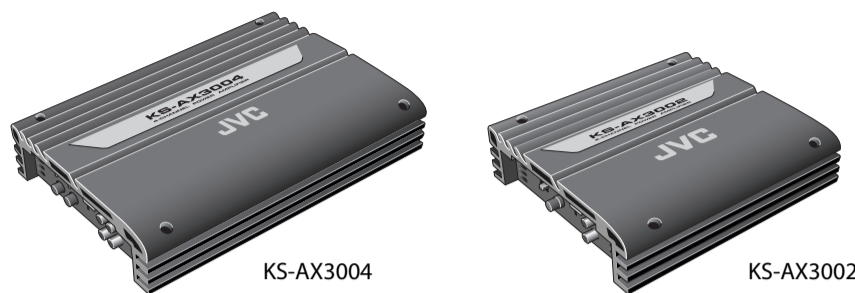

KS-AX3004

KS-AX3002

Thank you for purchasing a JVC product. Please read all instructions carefully before operation, to ensure your complete understanding and to obtain the best possible performance from the unit.

#### For safety...

- Do not raise the volume level too much, as this will block outside sounds, making driving dangerous.
- Stop the car before performing any complicated operations.

### CAUTIONS AND NOTES

This unit is designed to operate on **12 V DC, NEGATIVE ground electrical systems**.

- This unit uses BTL (Balanced Transformerless) amplifier circuitry, i.e., floating ground system, so comply with the following:
    - Do not connect the “⊖” terminals of the speakers to each other.
    - Do not connect the “⊖” terminals of the speakers to the metal body or chassis.
  - Cover the unused leads with insulating tape to prevent them from short circuiting.
  - When an extension lead is used, it should be as thick and short as possible; connect it firmly with insulating tape.
  - Be sure to leave an appropriate space between the antenna (aerial) and the wires of this unit.
  - When replacing the fuse, only use 25 A fuses.
  - Do not let pebbles, sand or metallic objects get inside the unit.
  - To keep the heat dissipation mechanism running effectively, wipe the accumulated dust off periodically.
  - Listening to the tape, radio, CD or digital audio player, etc. with the volume set at a high level for a long period of time will exhaust the battery, while the engine is turned off or while the engine is idling.
  - This unit becomes very hot. Be careful not to touch the unit not only when using but after using.
- DO NOT disassemble the unit since there are no user serviceable parts inside.*

**For Customer Use:** Enter below the Model No. and Serial No. which are located on the top or bottom of the cabinet. Retain this information for future reference.

Model No. \_\_\_\_\_

Serial No. \_\_\_\_\_

### INSTALLATION

The following illustration shows a typical installation. However, you should make adjustments corresponding to your specific car. If you have any questions or require information regarding installation kits, consult your “JVC IN-CAR ENTERTAINMENT” car audio dealer or a company supplying the kits.

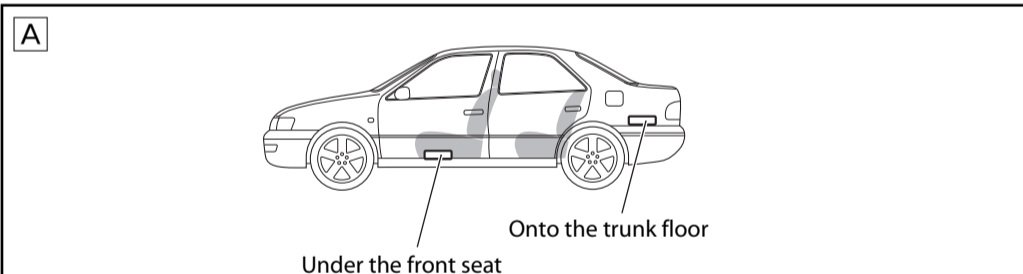

**Mount this unit on a firm surface, such as in the trunk or under the front seat.**

- Since heat is generated in the unit, do not mount it near inflammable objects. In addition, mount it in an area that will not prevent the unit from dissipating the heat.
- Do not mount the unit in the places subject to heat: near a radiator, in a glove compartment or in insulated areas such as under a car mat that will prevent the unit from dissipating heat.
- When mounting the unit under the front seat, make sure that adjusting the seat position will not catch any wire of the unit.

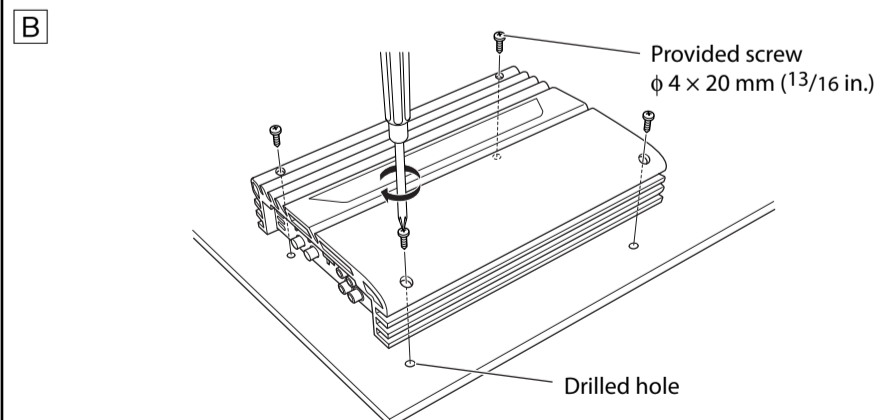

**When mounting this unit, be sure to use the provided screws.**

- If any other screws are used, there is a risk of loosening the unit or damaging the parts under the car floor.
- Before drilling holes in the trunk to install the unit, make sure that there is a sufficient space under the trunk so that you do not drill holes in the fuel tank, etc.

### POWER SUPPLY

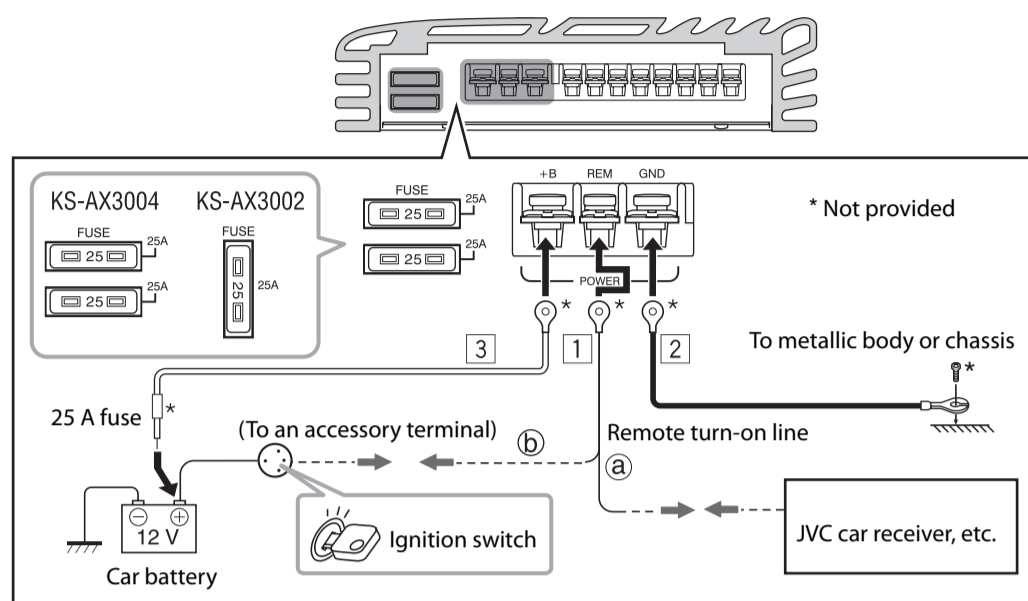

#### Caution

**To prevent short circuits while making connections, keep the battery's negative terminal disconnected.**

- 1 Remote turn-on line (not provided)
  - a When you use a JVC car receiver with a remote lead, connect to the remote lead.
  - b When you use a car receiver without a remote lead, connect to the accessory circuit of the car which is activated by the ignition switch. In this case, noise may occur when the car receiver is turned on or off. To avoid this noise, do not turn on or off the car receiver itself. You can turn it on or off along with the on/off operation of the ignition switch.
- 2 Ground lead (not provided)
- 3 Power cord (not provided)
  - When using a power cord, add a 25 A fuse near the battery as shown.
  - Connect to the battery's “+” terminal only after all the other connections have been made.

The proper lead connected to each POWER terminal is as follows:  
 – + B and GND: AWG 8 to AWG 4 (The cross section is about 8 mm<sup>2</sup> to 21 mm<sup>2</sup>.)  
 – REM: AWG 18 to AWG 8 (The cross section is about 0.8 mm<sup>2</sup> to 8 mm<sup>2</sup>.)

- Use ring terminals (not provided) for secure connection.

*If you have any questions regarding the thickness of the power cord, etc., consult your nearest “JVC IN-CAR ENTERTAINMENT” car audio dealer.*

### TERMINAL CONNECTIONS

When making terminal connections, properly fix each terminal with the provided screw by turning it as illustrated.

- Use ring terminals (not provided) for secure connection.

#### Notes

- Make sure the screw is fixed in place to prevent disconnections.
- Avoid over-tightening as it may cause the damage to the screw or its head slot.

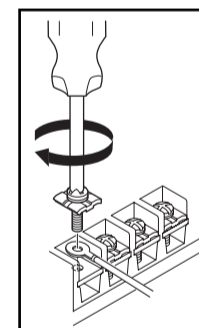

### SPEAKER SYSTEMS

This amplifier provides two types of speaker connections: Normal Mode and Bridge Mode connections.

You can choose either type depending on the speakers equipped on your car.

#### Notes

- Be sure not to connect the “⊖” terminals of the speakers to a common point.
- If the same lead is used for both left/right or front/rear speaker wirings, this unit cannot be used. Always use the independent leads for each speaker. In this case, redo the wirings.
- Use the speakers with an impedance of 2 Ω to 8 Ω (4 Ω to 8 Ω: when used in Bridge Mode).
- Use the speakers which have sufficient capacity to the unit.

The proper lead connected to each SPEAKER OUTPUT terminal is AWG 18 to AWG 12 (The cross section is about 0.8 mm<sup>2</sup> to 3.3 mm<sup>2</sup>).

# SPEAKER CONNECTIONS

Connection varies depending on the number of the speakers used in your car. Select the appropriate connection referring to the following diagrams.

## Notes

- Securely connect all the parts. If the connections are loose, due to contact resistance etc., heat will break out and may cause an accident.
- Run the connection leads under the car mats to prevent accidental disconnections.

- a** When your receiver is equipped with line output, connect the line output (through the receiver) to the INPUT jacks on this unit.
- b** When your receiver is NOT equipped with line output, connect the provided speaker input connector (through the receiver) to the HIGH INPUT terminal on this unit.
  - Connect each lead of the speaker input connector to a speaker positive lead or **chassis**\*1 of the receiver.
  - Cover the terminals of unused speaker negative leads of the receiver with insulating tape to prevent short circuits.

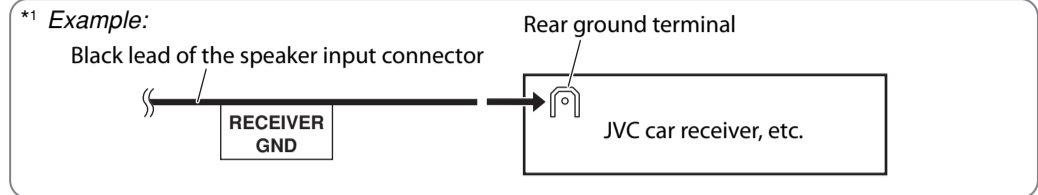

### KS-AX3004

#### 4-speaker system—Normal Mode

**a** JVC car receiver, etc.

Line out (Front) L R L R  
Line out (Rear) L R L R

Filter switches

CROSSOVER HPF OFF LFP  
CROSSOVER HPF OFF LFP  
CROSSOVER HPF OFF LFP  
CROSSOVER HPF OFF LFP

MIN LEVEL MAX LEVEL  
MIN LEVEL MAX LEVEL

HIGH INPUT

FRONT PEAKER OUTPUT REAR

Front speaker (Left/Right) L R  
Rear speaker (Left/Right) L R

**b** Speaker input connector

Connector lead	To	Receiver
A Gray "FRONT RIGHT (+)"	→	Front right (+) lead
B White "FRONT LEFT (+)"	→	Front left (+) lead
C Black "RECEIVER GND"	→	Chassis*1
D Purple "REAR RIGHT (+)"	→	Rear right (+) lead
E Green "REAR LEFT (+)"	→	Rear left (+) lead

---

#### 2-speaker system plus subwoofer—Bridge Mode

**a** JVC car receiver, etc.

Line out (Front) L R L R  
Line out (Rear) or Subwoofer out L R

Filter switches

CROSSOVER HPF OFF LFP  
CROSSOVER HPF OFF LFP  
CROSSOVER HPF OFF LFP  
CROSSOVER HPF OFF LFP

MIN LEVEL MAX LEVEL  
MIN LEVEL MAX LEVEL

HIGH INPUT

FRONT PEAKER OUTPUT REAR

Front speaker (Left/Right) L R  
Subwoofer

**b** Speaker input connector

Connector lead	To	Receiver
A Gray "FRONT RIGHT (+)"	→	Front right (+) lead
B White "FRONT LEFT (+)"	→	Front left (+) lead
C Black "RECEIVER GND"	→	Chassis*1
D Purple "REAR RIGHT (+)"	→	Rear right (+) lead
E Green "REAR LEFT (+)"	→	Rear left (+) lead

---

#### 2-speaker system—Bridge Mode

**a** JVC car receiver, etc.

Line out L R L R

Filter switches

CROSSOVER HPF OFF LFP  
CROSSOVER HPF OFF LFP  
CROSSOVER HPF OFF LFP  
CROSSOVER HPF OFF LFP

MIN LEVEL MAX LEVEL  
MIN LEVEL MAX LEVEL

HIGH INPUT

FRONT PEAKER OUTPUT REAR

Front speaker (Left/Right) L R

**b** Speaker input connector

Connector lead	To	Receiver
A Gray "FRONT RIGHT (+)"	→	Left (+) lead
B White "FRONT LEFT (+)"	→	Left (+) lead
C Black "RECEIVER GND"	→	Chassis*1
D Purple "REAR RIGHT (+)"	→	Right (+) lead
E Green "REAR LEFT (+)"	→	Right (+) lead

### KS-AX3002

#### 2-speaker system—Normal Mode

**a** JVC car receiver, etc.

Line out L R L R

Filter switch

CROSSOVER HPF OFF LFP  
CROSSOVER HPF OFF LFP  
CROSSOVER HPF OFF LFP  
CROSSOVER HPF OFF LFP

MIN LEVEL MAX LEVEL  
MIN LEVEL MAX LEVEL

HIGH INPUT

FRONT PEAKER OUTPUT REAR

Right speaker L R  
Left speaker L R

**b** Speaker input connector

Connector lead	To	Receiver
A White "LEFT (+)"	→	Left (+) lead
B Black "RECEIVER GND"	→	Chassis*1
C Gray "RIGHT (+)"	→	Right (+) lead

---

#### 2-speaker system (2 amplifiers)—Bridge Mode

**a** JVC car receiver, etc.

Line out L R L R

Filter switches

CROSSOVER HPF OFF LFP  
CROSSOVER HPF OFF LFP  
CROSSOVER HPF OFF LFP  
CROSSOVER HPF OFF LFP

MIN LEVEL MAX LEVEL  
MIN LEVEL MAX LEVEL

HIGH INPUT

FRONT PEAKER OUTPUT REAR

Left speaker L R  
Right speaker L R

**b** Speaker input connector

Connector lead	To	Receiver
A White "LEFT (+)"	→	Right (+) lead
B Black "RECEIVER GND"	→	Chassis*1
C Gray "RIGHT (+)"	→	Right (+) lead

---

#### Subwoofer system—Bridge Mode

**a** JVC car receiver, etc.

Line out (Rear) or Subwoofer out L R L R

Filter switch

CROSSOVER HPF OFF LFP  
CROSSOVER HPF OFF LFP  
CROSSOVER HPF OFF LFP  
CROSSOVER HPF OFF LFP

MIN LEVEL MAX LEVEL  
MIN LEVEL MAX LEVEL

HIGH INPUT

FRONT PEAKER OUTPUT REAR

Subwoofer

**b** Speaker input connector

Connector lead	To	Receiver
A White "LEFT (+)"	→	Left (+) lead
B Black "RECEIVER GND"	→	Chassis*1
C Gray "RIGHT (+)"	→	Right (+) lead

\*2 RCA pin cords (not provided)

## KS-AX3002 (for USA)

### 2-speaker system plus subwoofer (1 amplifier)

The minimum impedance should be 4 Ω for each of left and right speakers, and the subwoofer.

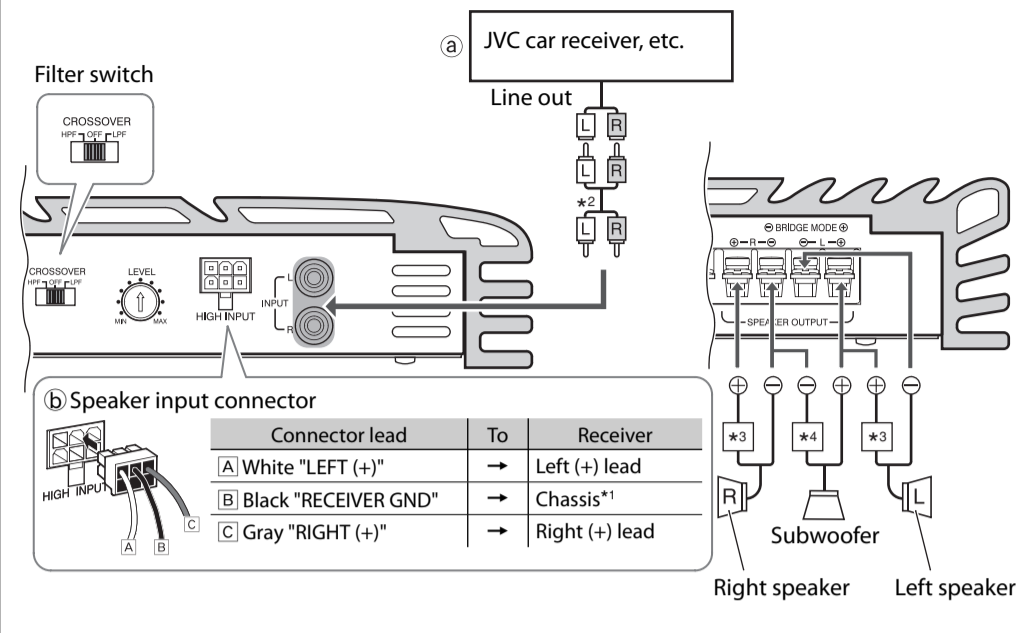

\*1 See page 2.

\*2 RCA pin cords (not provided)

\*3 Use a High-pass crossover (not provided)

\*4 Use a Low-pass crossover (not provided)

## CONTROLS

### KS-AX3004

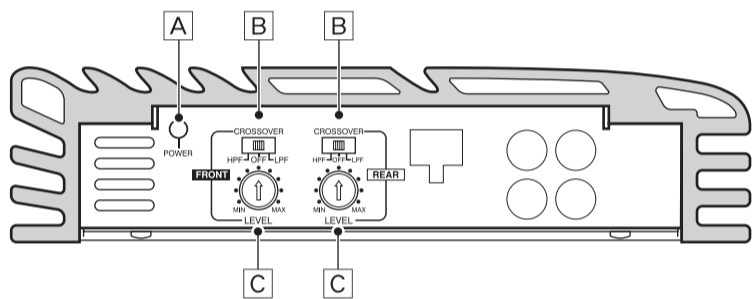

### KS-AX3002

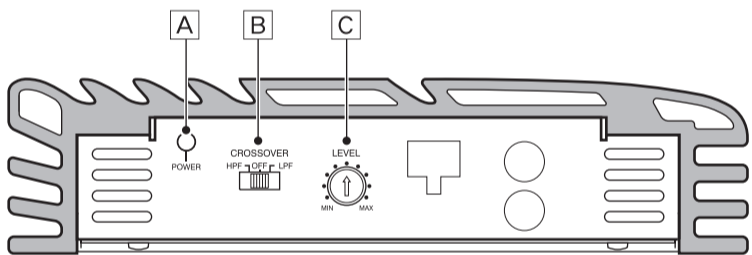

#### A POWER indicator

The green lamp lights while the unit is turned on.

#### B CROSSOVER filter switch

**OFF:** Normally set to this position. The switch is preset to this position when the unit is shipped.

**LPF:** Set to this position when you want to turn on the LPF (Low-Pass Filter) switch. The Low-Pass Filter transmits frequencies lower than 80 Hz.

**HPF:** Set to this position when you want to turn on the HPF (High-Pass Filter) switch. The High-Pass Filter transmits frequencies higher than 150 Hz.

#### C Input LEVEL controller

The input level can be adjusted with this control when this unit is connected to other source equipment. Adjust the level while listening to the sound. This control is preset to MIN when the unit is shipped.

## TROUBLESHOOTING

For more details, consult your "JVC IN-CAR ENTERTAINMENT" car audio dealer.

### The POWER indicator does not light.

- Change the fuses if the current one is blown.
- Connect the ground lead securely to a metal part of the car.
- Turn on the equipment connected to this unit.
- Confirm the battery voltage (11 V to 16 V).
- Use a relay if your system employs too many amplifiers.
- Leave the unit turned off to cool it down if it heats up abnormally.

### No sound is heard.

- Confirm the connections for the power supply (see "POWER SUPPLY" on page 1).
- Connect the RCA pin cords to the INPUT jacks, or the speaker input connector to the HIGH INPUT terminal.
- Confirm the speaker wirings and the position of the CROSSOVER filter switch (See "SPEAKER CONNECTIONS" on page 2).

### Alternator noise is heard.

- Keep the leads of the POWER terminals away from the RCA pin cords.
- Keep the RCA pin cords away from other electrical cables in the car.
- Connect the ground lead securely to a metal part of the car.
- Make sure the speaker negative leads do not touch the car chassis.
- Connect a bypass capacitor across the accessory switches (horn, fan, etc.).

### Noise is made when you connect the unit to an AM (MW/LW) tuner.

- Move all the leads of this unit away from the antenna (aerial) lead.

## SPECIFICATIONS

Power Output	<b>KS-AX3004:</b> • Normal Mode: 60 W RMS x 4 channels at 4 Ω and ≤ 1% THD + N <b>KS-AX3002:</b> • Normal Mode: 65 W RMS x 2 channels at 4 Ω and ≤ 1% THD + N
Signal-to-Noise Ratio	76 dBA (reference: 1 W into 4 Ω)



Power Output	<b>KS-AX3004:</b> • Normal Mode: 85 W RMS x 4 channels at 2 Ω and ≤ 1% THD + N • Bridge Mode: 120 W RMS x 2 channels at 4 Ω and ≤ 1% THD + N <b>KS-AX3002:</b> • Normal Mode: 90 W RMS x 2 channels at 2 Ω and ≤ 1% THD + N • Bridge Mode: 130 W RMS x 1 channel at 4 Ω and ≤ 1% THD + N
Maximum Power Output	<b>KS-AX3004:</b> 680 W (340 W x 2) <b>KS-AX3002:</b> 370 W
Load Impedance	• Normal Mode: 4 Ω (2 Ω to 8 Ω allowance) • Bridge Mode: 4 Ω (4 Ω to 8 Ω allowance)
Frequency Response	5 Hz to 50,000 Hz (+0 dB, -3 dB)
Input Sensitivity/Impedance	2 V/12 kΩ (0.3 V to 6 V, variable)
Distortion	Less than 0.04% (at 1 kHz)
Power Requirement	DC 14.4 V (11 V to 16 V allowance)
Grounding system	Negative ground
Dimensions (W×H×D)	<b>KS-AX3004:</b> 212 mm × 333 mm × 50 mm (8-3/8 in. × 12-5/8 in. × 2 in.) <b>KS-AX3002:</b> 212 mm × 196 mm × 50 mm (8-3/8 in. × 7-3/4 in. × 2 in.)
Mass (approx.)	<b>KS-AX3004:</b> 3.37 kg (7.42 lbs.) <b>KS-AX3002:</b> 1.94 kg (4.27 lbs.)
Accessories	Speaker input connector 6P × 1 Mounting Screw φ 4 × 20 mm (13/16 in.) × 4

Design and specifications are subject to change without notice.

### Information for Users on Disposal of Old Equipment



This symbol indicates that the product with this symbol should not be disposed as general household waste at its end-of-life. If you wish to dispose of this product, please do so in accordance with applicable national legislation or other rules in your country and municipality. By disposing of this product correctly, you will help to conserve natural resources and will help prevent potential negative effects on the environment and human health.

This symbol is only valid in the European Union.

### Dear Customer,

This apparatus is in conformance with the valid European directives and standards regarding electromagnetic compatibility and electrical safety.

European representative of Victor Company of Japan, Limited is:

JVC Technical Services Europe GmbH

Postfach 10 05 04

61145 Friedberg

Germany